

**Canopy**  
**Mini Pure'line 60 cm**  
**Stainless steel**



EAN 5414425008100

### Energy label

▪ Energy Efficiency class (EEIhood)	A
▪ Annual Energy Consumption (kWh/year) (AEChood)	34,9
▪ Fluid Dynamic Efficiency class (FDEhood)	A
▪ Lighting Efficiency class (LEhood)	A
▪ Grease Filtering Efficiency class (GFEhood)	C

### Functions & features

▪ Control method	Push buttons + Remote control
▪ Number of speeds	3 + power
▪ Automatic Power revert (minutes)	6
▪ Motor	Integrated
▪ Sound absorber	Integrated
▪ Recirculation	Optional
▪ InTouch function	Standard
▪ Auto stop	▪
▪ Delayed switch off (minutes)	10
▪ Number of grease filters	1
▪ Grease filter	609014
▪ Grease filter cleaning indication	▪
▪ Recirculation filter cleaning indication	▪

### Dimensions

▪ Product dimensions (WxDxH) (mm)	560 x 301 x 330
▪ Width flange (mm)	10
▪ Dimensions cut-out opening (WxD) (mm)	545 x 286
▪ Min dimensions cabinet (WxDxH) (mm)	x 600 x
▪ Advised mounting height induction hobs (Hmin-Hmax) (mm)	650 - 750
▪ Advised mounting height gas hobs (Hmin-Hmax) (mm)	650 - 750
▪ Advised mounting height ceramic hobs (Hmin-Hmax) (mm)	600 - 750
▪ Diameter outlet (mm)	150
▪ Position exhaust	Right, Top, Left, Back, Front

### Lighting

▪ Functional lighting type	Led
▪ Dimmable light	▪
▪ Soft-ON/OFF	▪
▪ Total energy consumption functional light (W)	8
▪ Color functional light	2700/4000

### Airflow and noise level

▪ Free airflow (m <sup>3</sup> /h)	815
▪ Airflow (m <sup>3</sup> /h) measured according to EN 61591	

## Airflow and noise level

---

▪ Sound regulation according to EN 60704-2-13	
▪ Airflow speed 1 (m <sup>3</sup> /h) / Max Pressure speed 1 (Pa)	205 / 79
▪ Airflow speed 2 (m <sup>3</sup> /h) / Max Pressure speed 2 (Pa)	333 / 219
▪ Airflow speed 3 (m <sup>3</sup> /h) / Max Pressure speed 3 (Pa)	399 / 322
▪ Airflow Powerspeed (m <sup>3</sup> /h) / Max Pressure Powerspeed (Pa)	534 / 370
▪ Sound pressure speed 1 (dB(A)) / Sound power speed 1 (dB(A))	26 / 37
▪ Sound pressure speed 2 (dB(A)) / Sound power speed 2 (dB(A))	37 / 49
▪ Sound pressure speed 3 (dB(A)) / Sound power speed 3 (dB(A))	42 / 54
▪ Sound pressure Powerspeed (dB(A)) / Sound Powerspeed (dB(A))	49 / 61

## Technical specifications

---

▪ Maximum power	118
▪ Voltage (V)	220-230
▪ Frequency (Hz)	50
▪ Length power supply cord (m)	1,3
▪ Power consumption in stand-by-mode (Ps) (W)	0.25

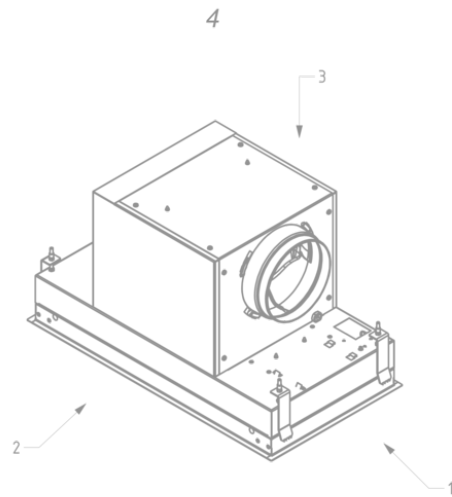
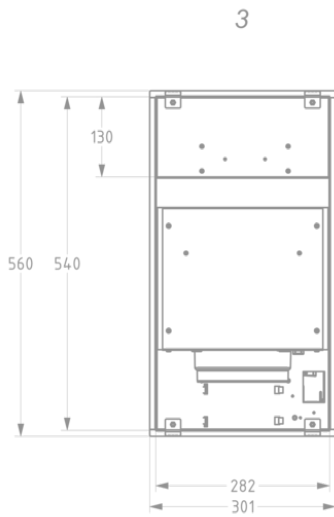
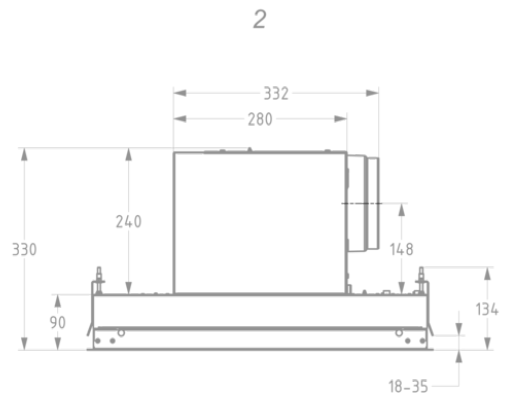
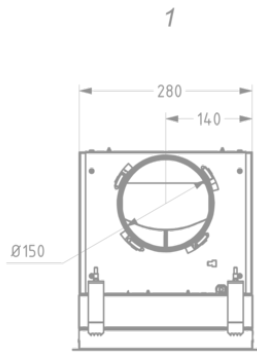

## Installation accessories

---

### Dissociated motor

- 800996

Kit to place motor at distance Mini Pure'line  
810/811/816/820/821/826 ≥V18

### Extension cable

- 700094

Extension cable 5 m

## Accessories

---

### Recirculation kit



811400

Recirculation set Mini Pure'line 810, 811 (370x149x20mm)

### Recirculation box



841400

recirculation box with monoblock white (270x500mm)



842400

recirculation box with monoblock black (270x500mm)



843400

recirculation box with monoblock grey (270x500mm)

### Control kit



990030

Control kit for external lighting or valve

